

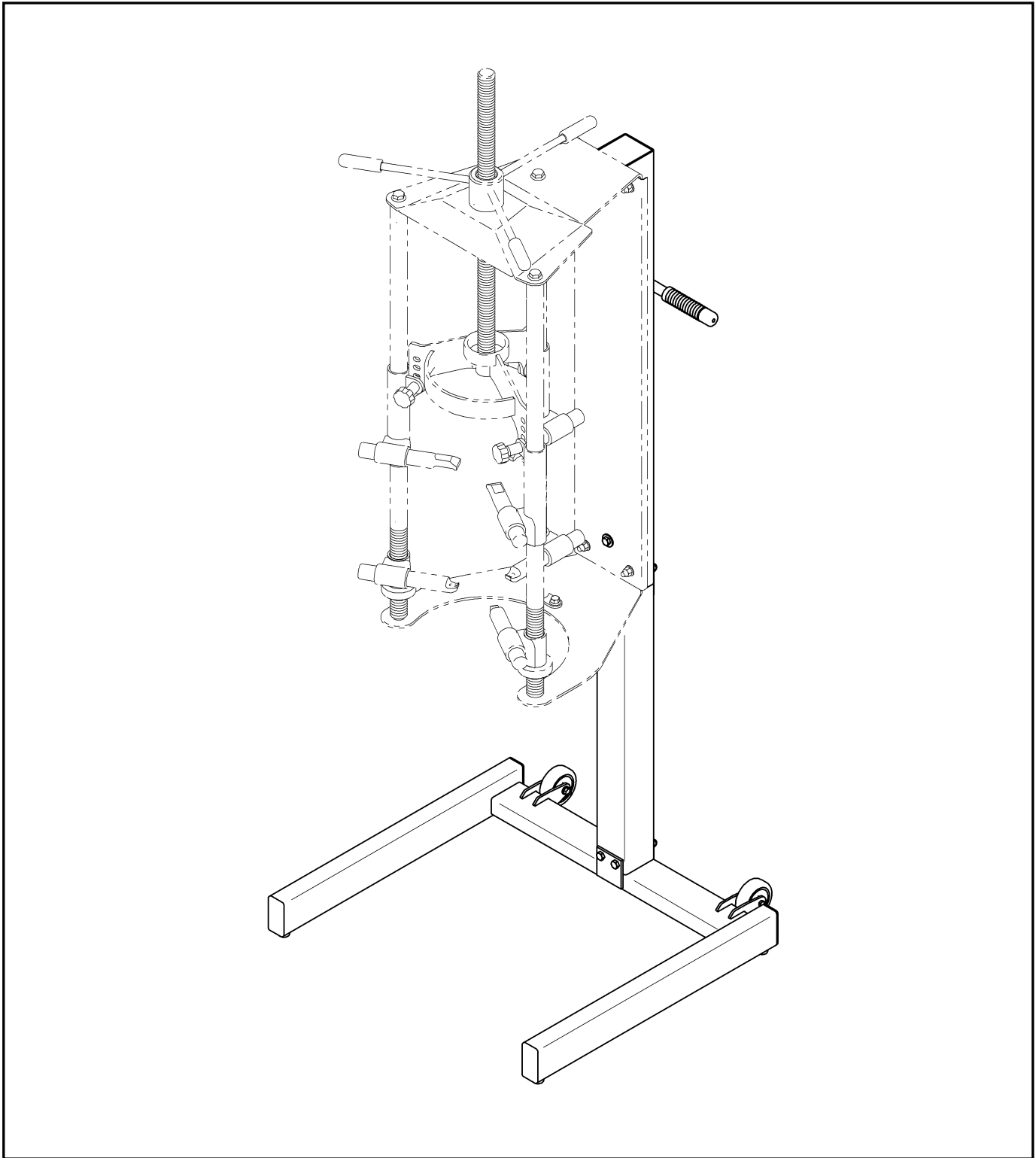

MODEL 764
PORTABLE CART
For use with Model 7600 / 7400

Installation, Operation
& Repair Parts
Information



Branick Industries, Inc. • 4245 Main Avenue • Fargo, North Dakota 58103

ASSEMBLY INSTRUCTIONS

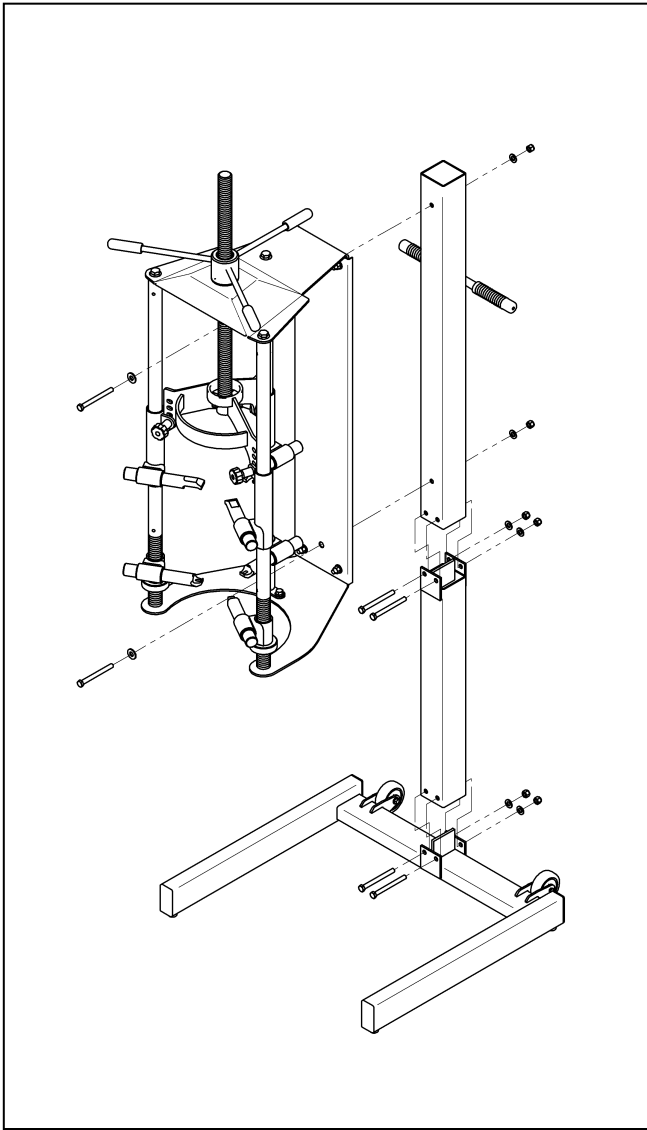

ASSEMBLY

Attach the lower column to the base as shown, using two 3/8-16 x 4" fasteners.

Attach the upper column to the lower column as shown, using two 3/8-16 x 4" fasteners.

Position the Model 7600 / 7400 on the front of the cart as shown and align the two holes in the back plate with the two holes in the upper column. Secure the Model 7600 / 7400 to the cart using two 3/8-16 x 4" fasteners with the larger washer on the bolt side and the smaller washer on the nut side.

OPERATION

To move cart, pull back on handles and tip cart back until the wheels contact the floor. Position cart in desired location and tip cart upright until all four pads are resting on the floor.

NOTE: All fasteners must be securely fastened before use.

*If the cart has any damage or missing parts,
Call Branick Industries, Inc. customer service at 1-800-437-4394*

REPAIR PARTS

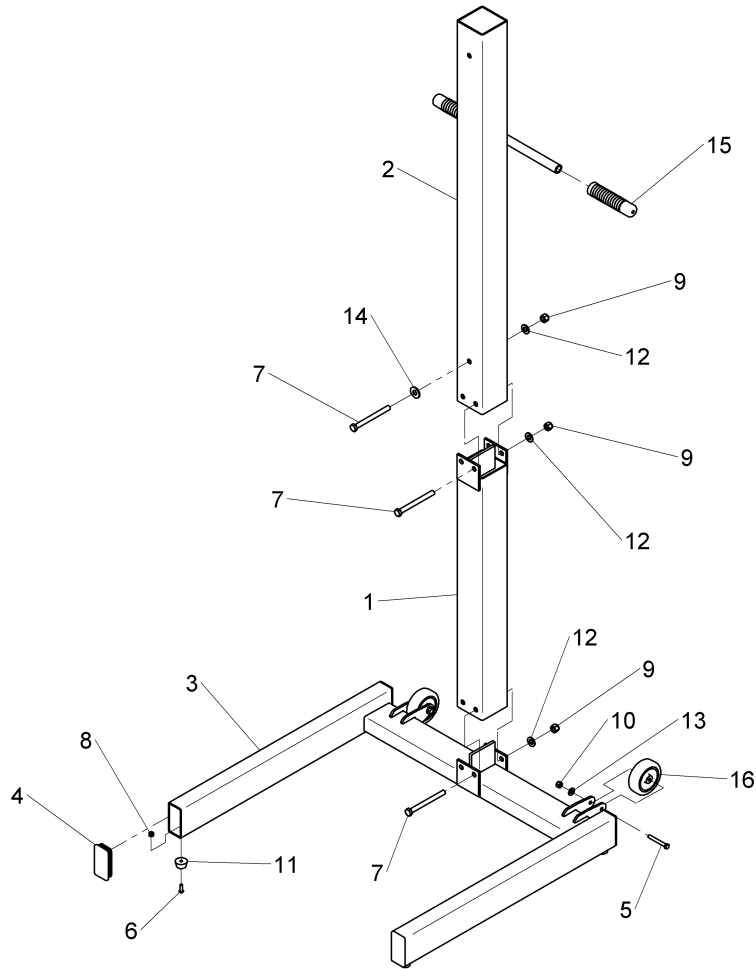

MODEL 764 – SERVICE PARTS

ITEM	PART NO.	QTY	DESCRIPTION
1	06-0036	1	LOWER COLUMN
2	06-0037	1	UPPER COLUMN
3	06-0197	1	BASE
4	11-0108	4	CAP PLUG
5	028-077	2	1/4-20 X 2 HEX HEAD CAPSCREW
6	028-155	4	#10-24 X 5/8 ROUND HEAD SCREW
7	028-341	6	3/8-16 X 4 HEX HEAD CAPSCREW
8	055-127	4	#10-24 NYLON HEX LOCK NUT
9	055-154	6	3/8-16 NYLON HEX LOCK NUT
10	055-160	2	1/4-20 NYLON HEX LOCK NUT
11	10-0032	4	RUBBER BUMPER
12	108-015	6	3/8 SAE FLAT WASHER
13	108-110	2	1/4 SAE FLAT WASHER
14	108-126	2	3/8 WROUGHT WASHER
15	550-002	2	HANDLE GRIP
16	90-0003	2	WHEEL

COMMERCIAL WARRANTY

This product is warranted by BRANICK INDUSTRIES, INC. to the original user-owner against defective materials or workmanship. During the warranty period, if Branick determines the product to be defective, it will be repaired or replaced (at Branick's option) without charge.

**Warranty Period
1 year from date of delivery.**

This warranty does not cover defects in the product caused by ordinary wear and tear, abuse, misuse, overloading, accident (including shipping damage), improper maintenance, alteration, or any other cause not the result of defective materials or workmanship.

REPLACEMENT IS THE EXCLUSIVE REMEDY FOR DEFECTIVE PRODUCT UNDER THIS WARRANTY. THIS WARRANTY IS EXPRESSLY IN LIEU OF ALL OTHER WARRANTIES, INCLUDING ANY IMPLIED WARRANTY OF MERCHANTABILITY OR ANY IMPLIED WARRANTY OF FITNESS FOR A PARTICULAR PURPOSE OF THIS PRODUCT. BRANICK INDUSTRIES, INC. SHALL NOT BE LIABLE FOR ANY CONSEQUENTIAL OR INCIDENTAL DAMAGES.

BRANICK INDUSTRIES, INC. reserves the right to make changes in the design or construction of our products without obligation to incorporate such changes in products already sold and without notice.

Service parts, warranty, and regular repair service are available from:

**BRANICK INDUSTRIES, INC.
4245 Main Ave.
Fargo, North Dakota 58103
701/281-8888**

